

Install the plastic Splash Guard with the holes located on the chalk line where the Pipe Supports will mount on the top stringer. Locate the first hole 15" from the inside of the framed opening (**Item 9, Figure 1**). Cut the excess plastic about an inch past the inside edge of the framed opening on both ends of the system (**See Figure 1**). Install a Pipe Support at each Splash Guard hole location making sure to keep Splash Guard pulled tight so as not to have any wrinkles.

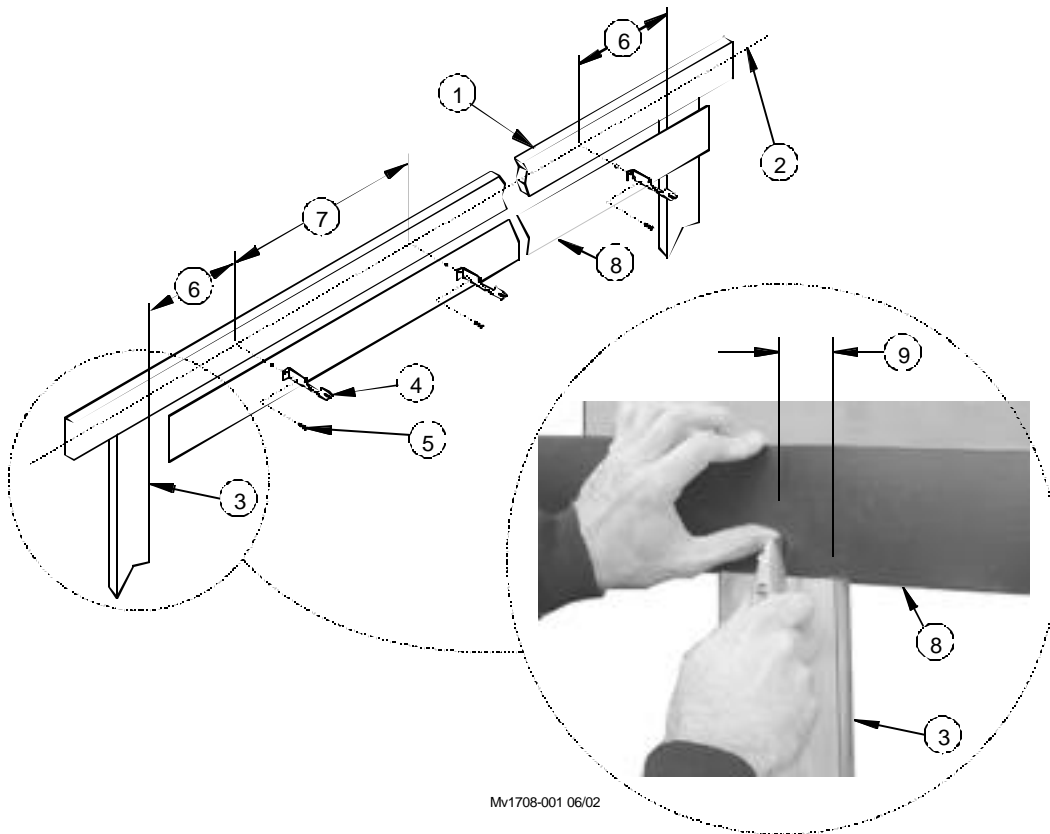

Mv1708-001 06/02

Item	Description
1	Top Stringer
2	Chalk Line
3	Inside of Framed Opening
4	Pipe Support
5	1/4 x 1-1/2 Lag Screw
6	15" (381 mm)
7	30" (762 mm)
8	Splash Guard
9	1"

Figure 1. Splash Guard Installation

Agile Manufacturing 720 Industrial Park Rd.  
Anderson, Missouri 64831 U.S.A.

Phone: 1-800-704-7356 • Web Site: [www.proterrasystems.com](http://www.proterrasystems.com) • E-Mail:  
[agile@agilemfg.net](mailto:agile@agilemfg.net)